

KEY

1. DPC
2. 280mm x 140mm back concrete cill
3. 20mm approved external render
4. 100mm Quinn Lite B5 blockwork
5. 40mm residual cavity
6. Flexible wall tie, butterfly or double triangle - BS1234 1978 or EN 845-1
7. 60mm Quinn Therm QW insulation
8. 25mm Quinn Therm QW insulation
9. Timber cill board
10. Quinn Lite block cut to size
11. 100mm Quinn Lite B5 blockwork
12. 12.5mm plasterboard on dabs or battens

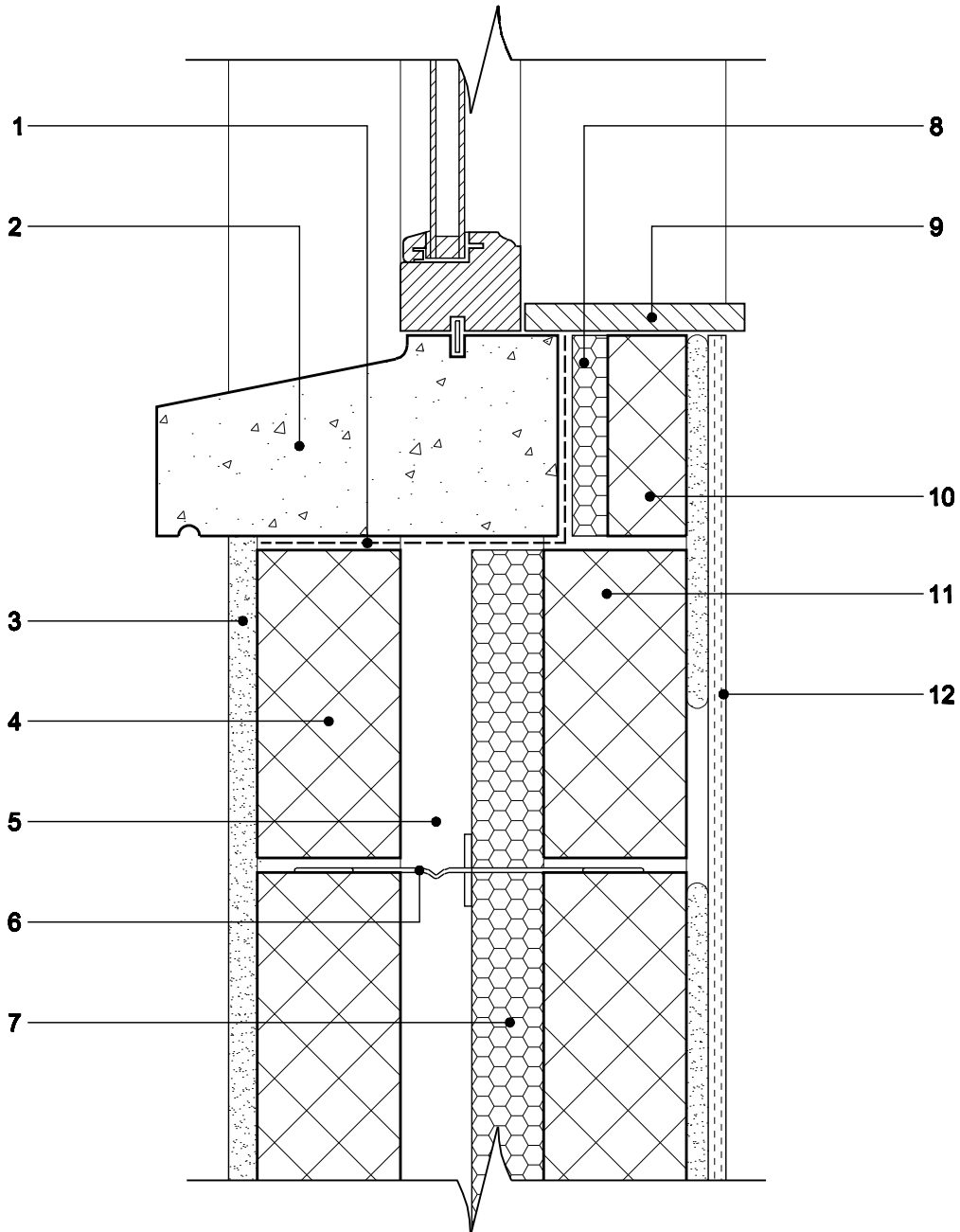

PROJECT	DRAWING TITLE Cill Detail	DRAWING NO.	REVISION
copyright© The information is supplied in good faith and no liability can be accepted for any loss or damage resulting from use.	QUINN REF QL-TD-004	DATE	SCALE 1.5
QUINN group	Quinn Group, Head Office, Derrylin, Co. Fermanagh, BT92 9AU Tel:+44 (0) 28 6774 8866 Fax: +44 (0) 28 6774 8800 Email: General Enquires: info@quinn-group.com Technical Enquires: technical@quinn-group.com		