

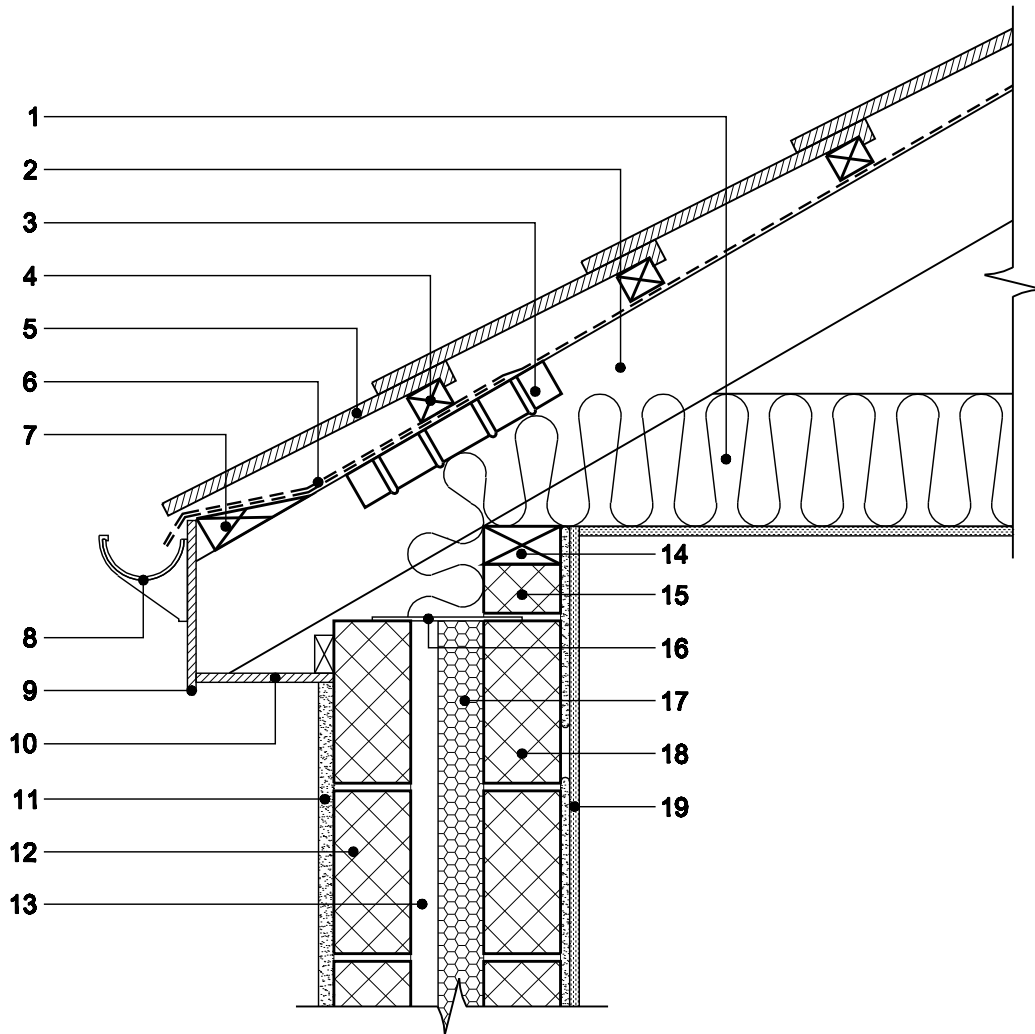

**KEY**

- |                                    |                                      |
|------------------------------------|--------------------------------------|
| 1. Mineral Wool Insulation         | 11. Approved External Render         |
| 2. Rafter                          | 12. 100mm Quinn Lite B5 block work   |
| 3. Eaves ventilation               | 13. 40mm cavity                      |
| 4. Battens at max 320mm gauge      | 14. Timber wallplate                 |
| 5. 420x334mm Quinn Rooftile        | 15. Quinn Lite coursing unit         |
| 6. Underfelt (carried into gutter) | 16. Cavity closer                    |
| 7. Angle Fillet                    | 17. 60mm Quinn Therm (QW) insulation |
| 8. Gutter                          | 18. 100mm Quinn Lite B5 blockwork    |
| 9. Fascia board                    | 19. 12.5mm plasterboard on dabs      |
| 10. Soffit with ventilation holes  |                                      |



PROJECT	DRAWING TITLE <b>Standard Eaves Detail</b>	DRAWING NO.	REVISION
copyright© The information is supplied in good faith and no liability can be accepted for any loss or damage resulting from use.	QUINN REF <b>QL-TD-010</b>	DATE	SCALE <b>1.10</b>
 Quinn Group, Head Office, Derrylin, Co. Fermanagh, BT92 9AU Tel:+44 (0) 28 6774 8866 Fax: +44 (0) 28 6774 8800 Email: General Enquires: info@quinn-group.com Technical Enquires: technical@quinn-group.com			